

TECHNICAL SPECIFICATIONS

Ball Check Valves Sizes 1" - 4"
Series 410 Fiberglass Reinforced Polysulfone



1. SCOPE

Ball Check Valves for corrosive chemical service used in construction of pressurized piping systems.

2. SERVICE RATING

Temperature rating from -50 to 275° F as shown on pressure/temperature chart on the reverse side. See Catalog 1000 for temperature limits for specific chemicals.

3. MATERIALS OF CONSTRUCTION

- (1) **Body:** Compression molded glass fiber and polysulfone resin, complete with integrally molded ball guides.
- (2) **Ball:** Solid Virgin PTFE.
- (3) **Seat:** PTFE-coated Viton
- (4) **Body O-Ring:** PTFE-coated Viton.
- (5) **Body Insert:** Glass fiber reinforced polysulfone.

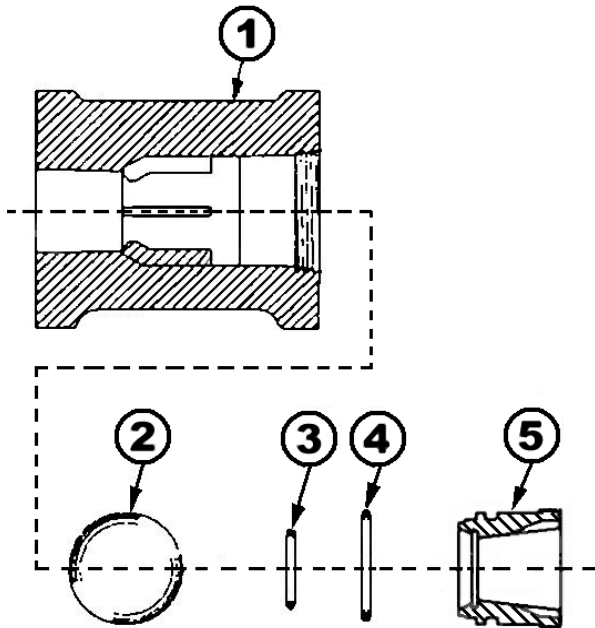

4. DESIGN

- Valves shall be flanged and conform to the face-to-face dimensions of ANSI/ASME B16.10.
- Flanges shall be flat-faced with serrated finish to allow installation in metallic, lined metal, FRP, and thermoplastic piping systems.
- Flange bolt sizes and spacing shall conform to ANSI B16.5 Class 150. DIN, JIS and BS shall be available.
- Vertical pressure drop to unseat shall be less than 1 psi.
- Horizontal reseal velocity in liquid flow shall not exceed 2 feet/sec.

5. QUALITY ASSURANCE

- The Manufacturer's facility shall be certified to ISO 9001 or equivalent. The Manufacturer shall be certified to the European Pressure Equipment Directive (PED) and the "CE" mark shall be affixed to each valve label.
- Each valve shall be hydrostatically shell tested at no less than 1.43x its rated cold working pressure for 3 minutes.
- Each valve shall be seat tested with water at 20 and 165 psig. No visible leakage shall be permitted for the duration of the tests.

6. PACKING AND SHIPPING

- Valves shall be shipped with both ends capped to exclude dirt and properly boxed to avoid damage.
- Each valve shall be marked with the manufacturer, valve size, model, serial number, and valve component designations.

7. AVAILABILITY

Valves meeting this specification are available from:

Nil-Cor®, LLC
4855 Broadmoor Ave.
Kentwood, MI 49512
P: 616-554-3100
F: 616-554-5623
www.nilcor.com

Pressure/Temperature Rating

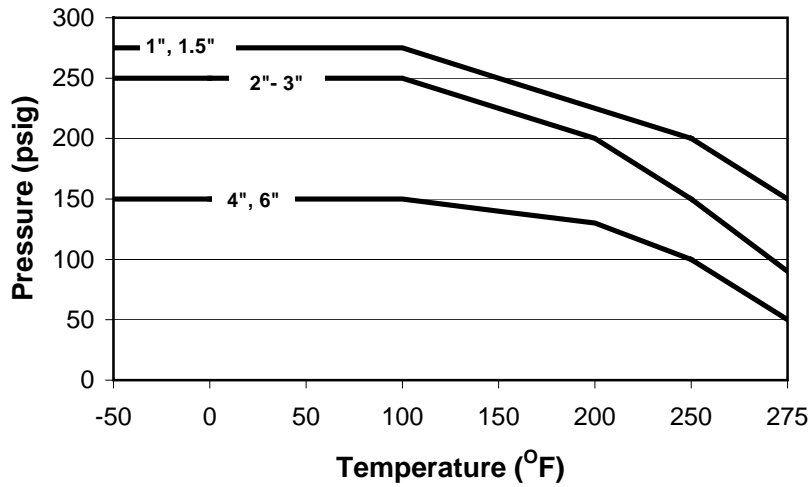

Installation Dimensions (Inches)

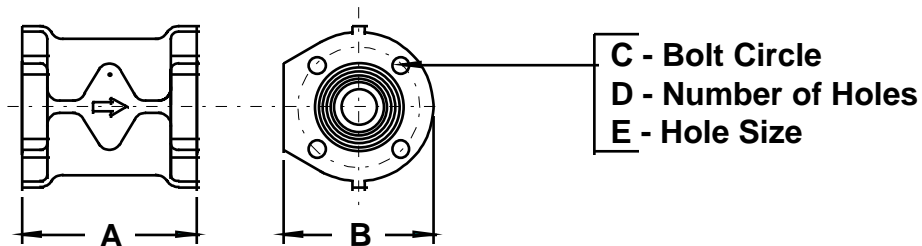

Size	A	B	C	D	E	Weight: lbs (kg)	Cv
1	5.00	4.25	3.13	4	5/8"	3 (1.4)	32
1-1/2	6.50	5.00	3.88	4	5/8"	6 (2.7)	45
2	7.00	6.00	4.75	4	3/4"	8 (3.6)	50
3	8.00	7.50	6.00	4	3/4"	14 (6.4)	155
4	9.00	9.00	7.50	8	3/4"	23 (10.5)	275