

# TECHNICAL SPECIFICATIONS

Lug Butterfly Valves: 3" - 12" Series 300HD  
Graphite Fiber-Reinforced Vinyl Ester



## 1. SCOPE

Double-Offset Wafer style Lug Body High Performance Composite Butterfly Valves for corrosive chemical service used in construction of pressurized piping systems.

## 2. SERVICE RATING

Continuous temperature service from 0° to 250° F. Short-term exposures to 300° F are acceptable.

Pressure ratings are as shown on P/T chart on reverse side of this page.

## 3. MATERIALS OF CONSTRUCTION

1. **Body:** Graphite Fiber-reinforced vinyl ester resin
2. **Retainer Ring:** Graphite Fiber-reinforced vinyl ester resin
3. **Seat:** Viton GF or PTFE.
4. **Disc:** Vinyl ester resin reinforced with graphite fiber (3"-8") or glass fiber (10", 12").
5. **Shaft:** 17-4 PH stainless steel encapsulated with graphite fiber-reinforced vinyl ester on all wetted surfaces.
6. **Shaft Retainer Pin:** Graphite-filled PVDF
7. **Packing Follower:** Hastelloy-C
8. **Packing Bolts:** Hastelloy-C
9. **Shaft Seals:** PTFE-V-Ring Packing

## 4. DESIGN

- Valve seat and disc geometry shall provide a 360° uninterrupted bubble tight seal from full vacuum to rated valve pressure.
- Valves shall have a double-offset disc and thru-shaft to provide superior disc support, reduced torque and seat wear.
- Face-to-face dimensions shall conform to ANSI B16.10 CL 150 Extra-Wide Pattern BFV as shown on Page 2.
- Stems shall be of blowout proof design.
- Valve design shall be such that it can be bolted into a standard PTFE-lined steel pipe and the valve disc not interfere with the lining of the pipe.
- Gear or lever handle shall be available on all sizes.
- Valves shall have Standard ISO 5211 shafts and mounting patterns.
- Valves shall be capable of on-off actuation or modulating control with pneumatic, electric or hydraulic actuators.

## 5. TESTING

- The Manufacturer's facility shall be certified to ISO 9001 or equivalent. The Manufacturer shall be certified to the European Pressure Equipment Directive (PED) and the "CE" mark shall be affixed to each valve label.
- Each valve shall be hydrostatically tested with water at not less than 1.5 times its operating pressure limit with the disc open and both ends blanked with no evidence of leakage.
- Each valve shall be subjected to a hydrostatic seat test at not less than 110% of the rated shutoff pressure and an air test at 20 psig with no evidence of leakage.

## 6. PACKING AND SHIPPING

- Valves shall be shipped in the closed position.
- Each valve shall be marked with the manufacturer, size, series, construction materials, serial number, and valve component designation.

## 7. AVAILABILITY

Valves meeting this specification are available from:

Nil-Cor®, LLC  
4855 Broadmoor Ave. S.E.  
Kentwood, MI, USA 49512  
(616) 554-3100  
[www.nilcor.com](http://www.nilcor.com)

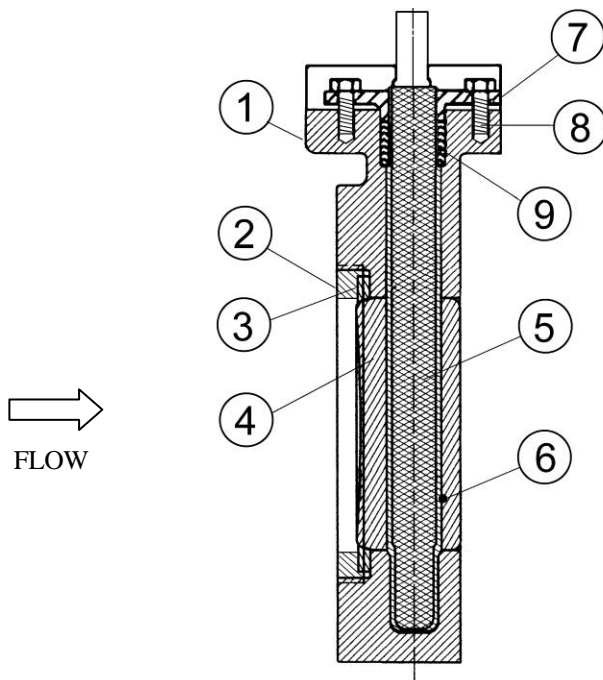

# Nil-Cor® LUG WAFER BUTTERFLY VALVE DIMENSIONS

All dimensions are in Inches unless otherwise noted

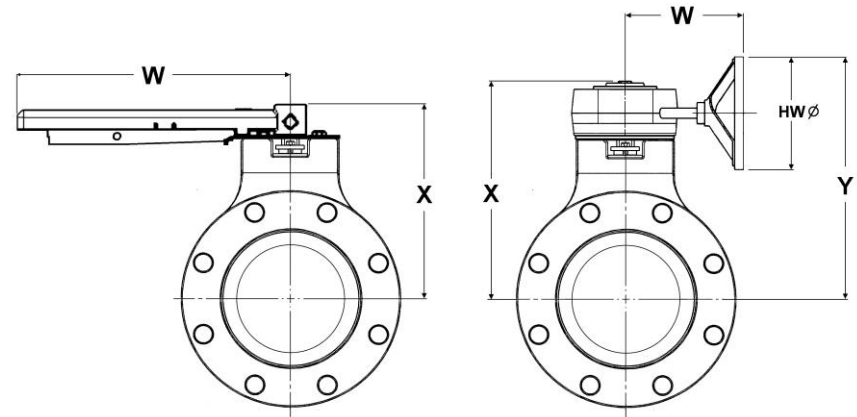
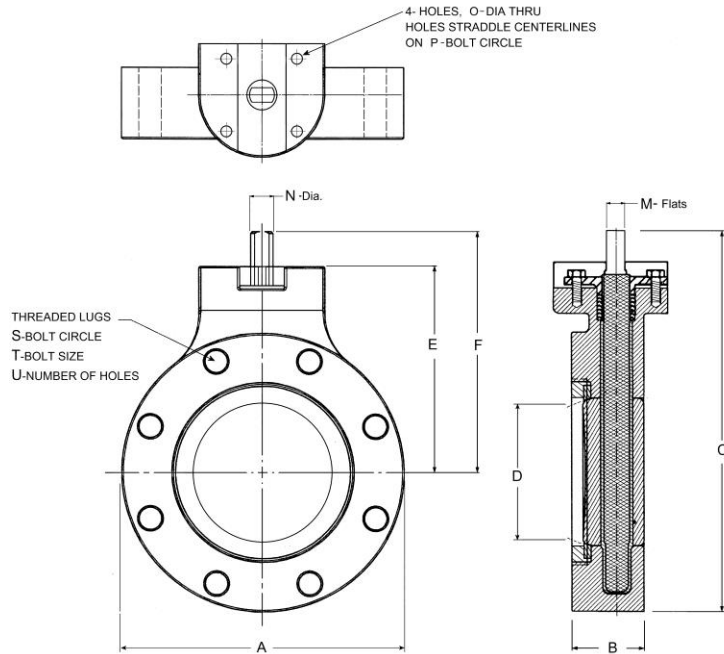

SIZE	A	B	C	D	E	F	S	T	U
3	7.50	2.060	11.31	2.50	6.38	7.56	6.00	5/8 - 11	4
4	9.00	2.300	13.31	3.47	7.13	8.81	7.50	5/8 - 11	8
6	11.00	2.810	15.00	5.38	8.13	9.50	9.50	3/4 - 10	8
8	13.50	2.940	18.13	7.56	9.50	11.38	11.75	3/4 - 10	8
10	16.00	3.130	21.31	9.40	11.38	13.31	14.25	7/8 - 9	12
12	19.00	3.380	24.44	11.42	12.88	14.94	17.00	7/8 - 9	12

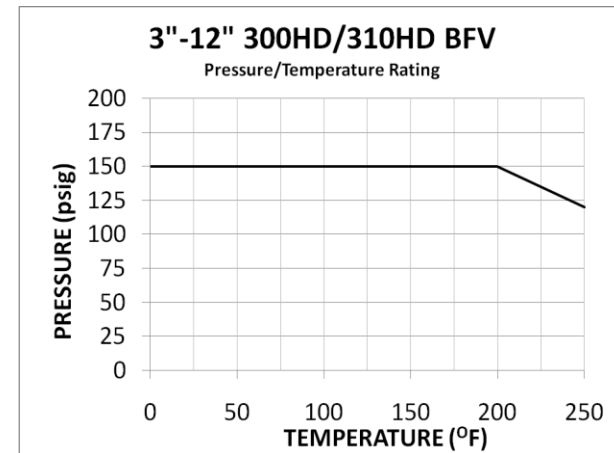

SIZE	ACTUATOR MOUNTING DIMENSIONS				LEVER DIMENSIONS		GEAR DIMENSIONS			HW	Cv	OPERATING TORQUE (IN-LBS)		WEIGHT (LBS.)		
	M (+.000 / -.002)	N	O	P	W	X	W	X	Y			<50 psid	>50 psid	BARE	W/LEVER	W/GEAR
3	0.433	0.555	0.345	2.756	14.00	8.13	5.48	8.83	10.44	6.00	220	240	240	7.5	11.4	11.5
4	0.551	0.713	0.423	4.016	14.00	8.88	5.48	10.08	11.69	6.00	395	360	480	12.6	16.5	16.6
6	0.669	0.874	0.423	4.016	14.00	9.86	6.91	10.94	12.33	6.00	950	780	960	19.0	22.9	26.0
8	0.866	1.110	0.423	4.016	14.00	11.21	7.53	12.31	14.70	8.00	2250	1680	2160	25.7	29.6	32.7
10	1.063	1.425	0.502	4.921	NA	NA	9.24	13.85	18.75	12.00	3640	2400	4200	44.0	NA	59.0
12	1.063	1.425	0.502	4.921	NA	NA	9.24	15.81	21.25	14.00	5180	3960	6360	65.0	NA	80.0